

AEROPHYSICS RESEARCH

CENTER



Hypervelocity Interior Ballistics Free-Flight Test Range



Key Benefits of Ground Testing in a Ballistics Range

Experiments performed in a ballistic range are low cost relative to full-scale missile flight tests (10's of thousands versus 10's of millions of dollars). Experiments in the range can be implemented on a relatively fast turnaround basis – weeks versus months to years for full-scale tests. The relatively low cost and rapid response is useful in the early stages of program definition by providing the capability for screening concepts for down-select of program options. Experimental data at critical peg points can also reduce risks by validating computer simulations.

Principal Applications

The two major areas of application for this facility are in phenomenology related to hypervelocity impact and hypervelocity flight in the earth's atmosphere. The applications in hypervelocity impact include the development and evaluation of the lethality of kinetic energy weapons for strategic and tactical systems and kill assessment. The hypervelocity impact tests can involve single or multiple fragments, single or multiple rods and various configurations of hit-to-kill vehicles. The University of Alabama in Huntsville, Aerophysics Research Center (UAH/ARC) has demonstrated capabilities to evaluate test parameters which can include projectile mass, material(s), configuration, relative strike velocity, strike angle, active attitude control of projectile pitch/yaw and shot line as well as various target configurations and materials.

The hypervelocity flight phenomenology tests can be used for studies of signature and hypersonic flow related to re-entry, the effects of high-speed flight on interceptor sensors, and for propulsion research with regard to high-speed vehicle/inlet flow and combustion. The range has proven its value in developing the understanding of the physical basis for coherent radar signatures scattered from the body and wakes of re-entry vehicles. The ballistics range has also demonstrated its capability to determine the effects of boundary layer plasma on the bore-sight error of millimeter wave sensors on-board interceptors. For aero-optics and aero-thermal effects studies, it is possible to perform experiments in which $\frac{1}{4}$ to about $\frac{1}{2}$ scale fore-body models of the interceptor configuration are launched at full-scale flight velocities. High-speed flow and combustion can be investigated by launching scaled models under free-flight conditions through various simulated altitudes from ground level to about 65 km.

Goals

The goals of the UAH/ARC are to perform contract research for government agencies and corporations and to provide training and research opportunities for undergraduate and graduate students as well as for the academic staff. The goals also are to work closely with local large and small businesses to win team/joint programs that will enhance the resources and capabilities of this center.

Contact Information

U.S. Army Space and Missile Defense Command
P.O. Box 1500
Huntsville, AL 35807-3801
256-955-3887 DSN 645-3887
Fax 256-955-1214

254 MM TWO-STAGE LIGHT GAS GUN



125' Long x 10" Diameter Pump Tube
75' Long Interchangeable Launch Tubes
Launch Tube Diameters from 2.2" to 6.0"



10' Diameter x 41' Long Impact Chamber

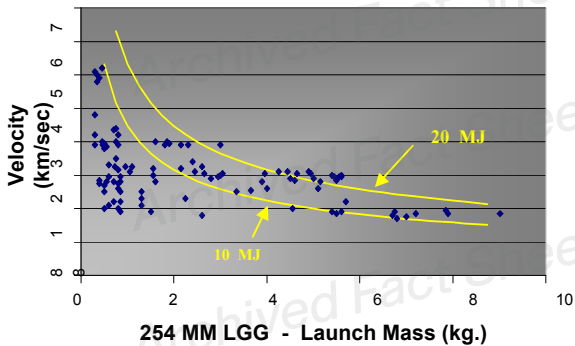

Launch Mass's up to ~ 10 kg.
Launch Energy's up to ~ 25 MJ.



133 MM LGG
LT Diam. of 1.38" & 1.15"



108 MM LGG
LT Diam. of 0.75" & 1.15"

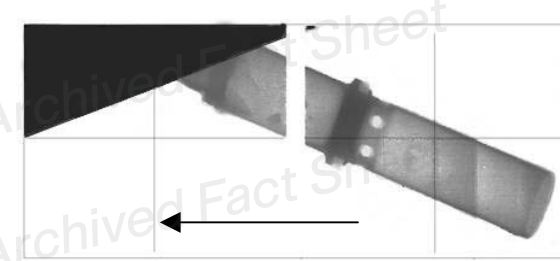
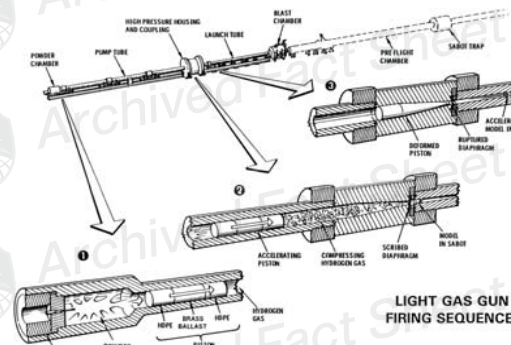
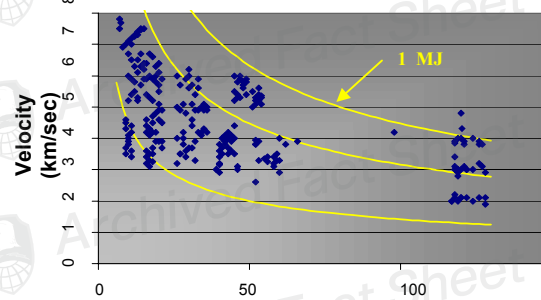
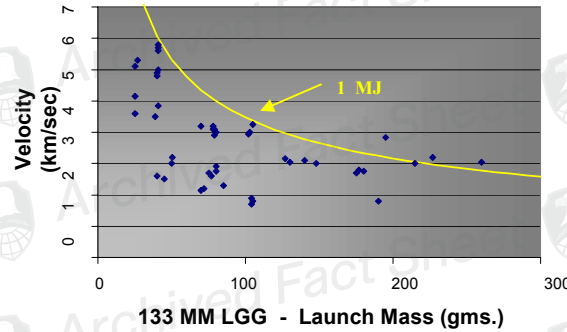

Tilt Model Engaging Target



High-Speed Flow Over Nosecones

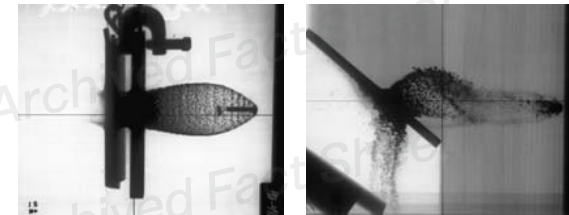

Hypervelocity Rod Impact

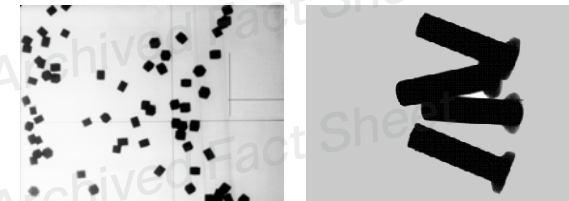

Fragment and Multi-Rod WH Lethality Effects



Long Rod Penetrator